

STAIR #1 3D-VIEW

A	02/13/2020	For Approval
REV.	Date	Description
CCSU ENGINEERING BUILDING MECHANICAL FENCE CAP		
STEEL:		 <p>PROIRON 1 CALLEGARI DR WEST HAVEN CT 06516 TEL:203/967-2020 CCSU ENGINEERING BUILDING 1615 STANLEY STREET, NEW BRITAIN CT 06053</p>
WELD:		
HOLE SIZE:		
BOLTS:		
FINISH:		
SURFACE PREP:		SCALE:
DRY FILM THICKNESS:		SCALE:
REVISIONS		REVISIONS
△	DRAWN BY: SRI	△
△	CHECKED BY: GVK	△
△	DATE: 1581562000	△
△	JOB NUMBER: PROJ-NUM	△

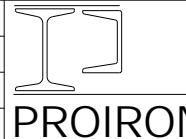
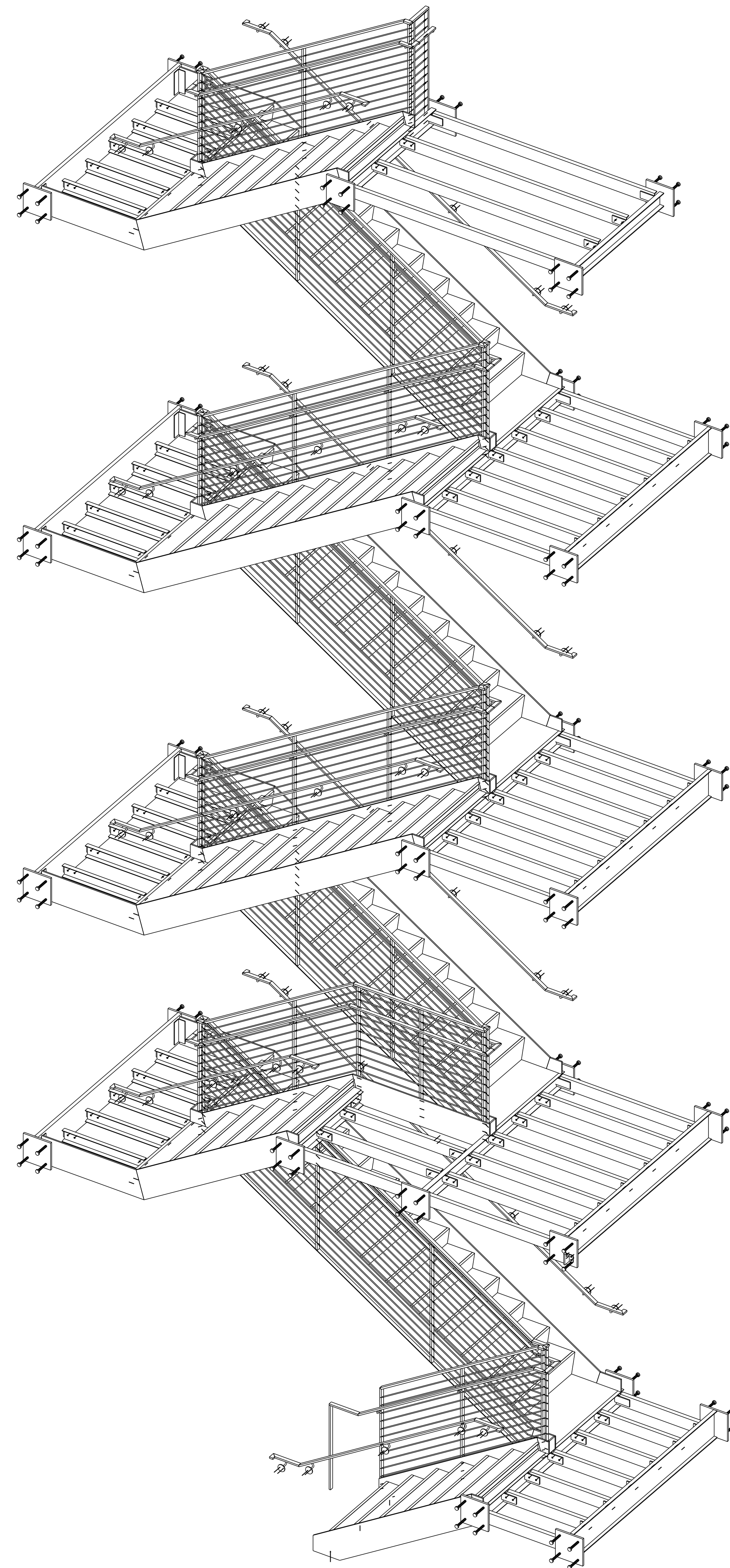

STAIR 2 - ISOMETRIC VIEW
(REF:2/A702)

NO.	DATE	REVISIONS
1	07/05/2019	For Re-Approval
2	06/14/2019	For Approval

PAINT		PRIMER-TNEMEC#115		AMERICAN STEEL AND STAIRWAY, INC. 8525 FOREST STREET GILROY, CALIFORNIA 95020 (408) 848-2992	
HOLES U.N.O.		13/16"Ø HOLES (U.N.O)			
GEN. NOTES					
STAIR 2 - ISOMETRIC VIEW					
TITLE					
JOB 1125 MERRILL STREET					
LOCATION MENLO PARK, CA 94025					
ARCH.		FIELD ARCHITECTURE		CONTRACTOR	
BY	BVK	CHK	VHR	DATE	06/14/2019
APPROVAL DATE		TOTAL		JOB NO. 8862 DWG.E201	

SUBMITTAL APPROVAL RECD. IN SHOP

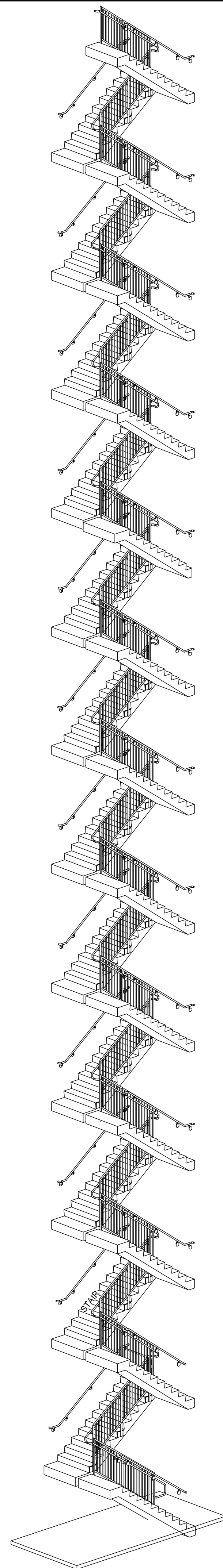

STAIR-02 ISOMETRIC VIEW
(REF:A410)

APPROVAL/REVIEW AUTHORITY:
PLEASE REVIEW THE DRAWINGS CAREFULLY.
THIS DRAWING REPRESENTS OUR BEST INTERPRETATION
OF THE INTENT OF THE CONTRACT DOCUMENTS. MANOWSKE
WELDING CORP. ASSUMES NO RESPONSIBILITY FOR THE
ACCURACY OF THE CONTRACT DOCUMENTS.
UNLESS NOTED TO THE CONTRARY ON THIS DRAWING,
WHEN IT IS RETURNED FROM APPROVAL,
IT WILL BE ASSUMED THAT ALL INFORMATION
INCLUDING CONNECTIONS, SHOWN HEREIN HAS THE
AFFIRMATION OF THE APPROVAL AUTHORITY.
SUBSEQUENT CHANGES TO INFORMATION SHOWN ON
THIS DRAWING AFTER APPROVAL HAS BEEN RECEIVED
WILL BE CONSIDERED AS CONTRACT CHANGES.

		Manowske Welding Corp. 821 South Military Road Remit To: P.O. Box 427 Fond du Lac, WI 54936-0427 United States of America Ph: 920-922-3340 Fax: 920-922-3341		
MANOWSKE WELDING CORP.				
Project: RENAISSANCE HOTEL MILWAUKEE WEST				
Location: WAUWATOSA, WI 53226				
Customer: MARRIOTT				
Architect: KAHLER SLATER				
Job No.	19079	Date:	04/08/2019	
Drawn By:	BVK	Checked:	VHR	
NOTES				
1) All holes 13/16 dia. u.n.o. 2) Paint: GRAY SHOP PRIMER 3) Finish: SSPC-SP1 & SP6 4) Materials A36 u.n.o. 5) Welds E70XX				
Issue	Date	For	By	
A	04/08/2019	FOR APPROVAL	BVK	
0	06/20/2019	For Field Use	BVK	

ME7

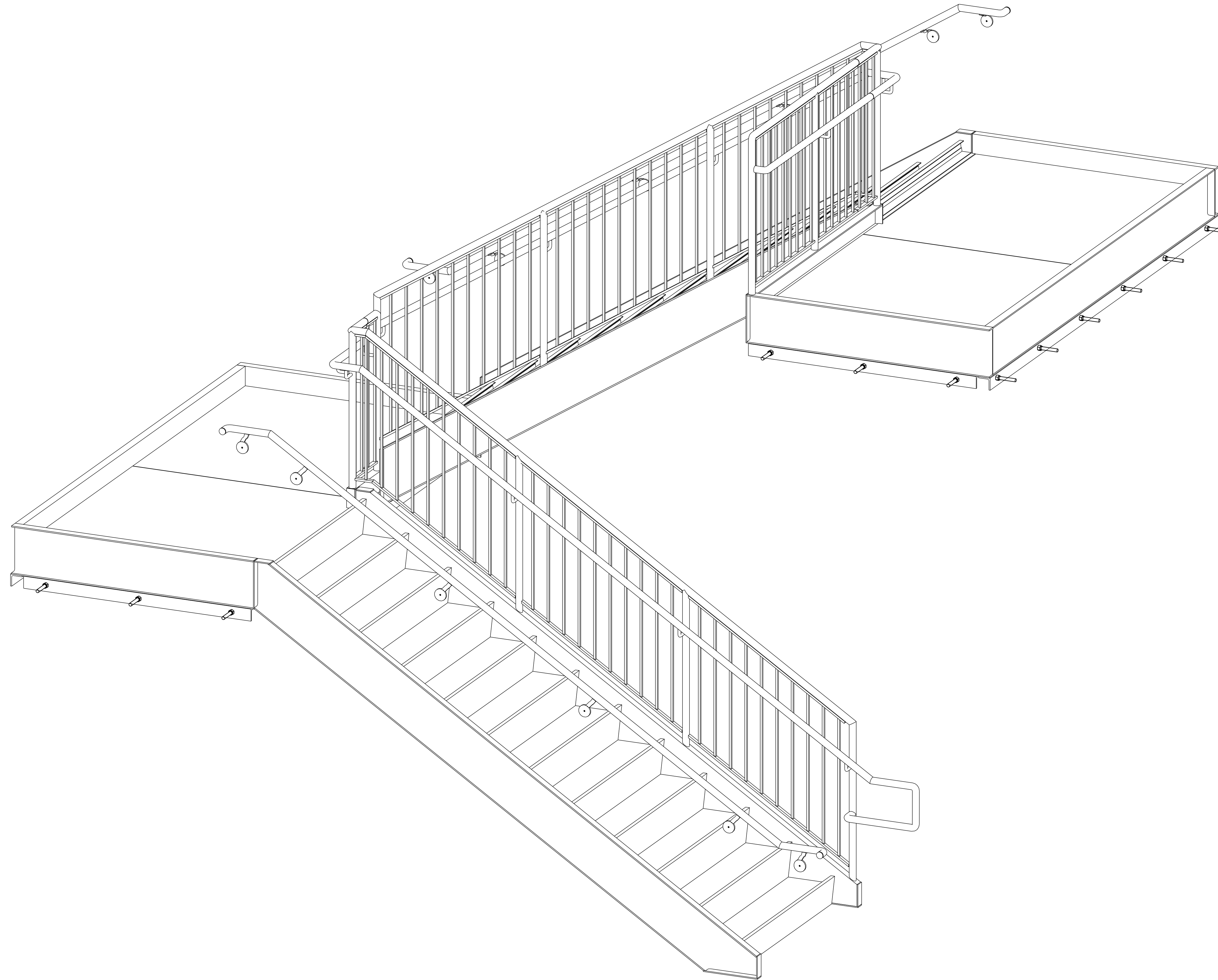

STAIR-A ISOMETRIC VIEW
 (AREA-A)
 (REF:A9.1)

DESCRIPTION: STAIR-A ISOMETRIC VIEW	
JOB: SHANNODALE RETIREMENT CENTER	
CUSTOMER: -	ARCHITECT: COOPER ARCHITECTURE
Tennessee River Steel, LLC. Post Office Box 639 Hollywood, AL. 35752 Phone: (256) 574-2755 Fax: (256) 259-4247	
DRAWN BY	DATE
BVK	28.03.2019
CHKD. BY	DATE
VHR	28.03.2019
DRG. NO.	REV.
E101	A

A	03/28/2019	For Approval
REV.	DATE	DESCRIPTION

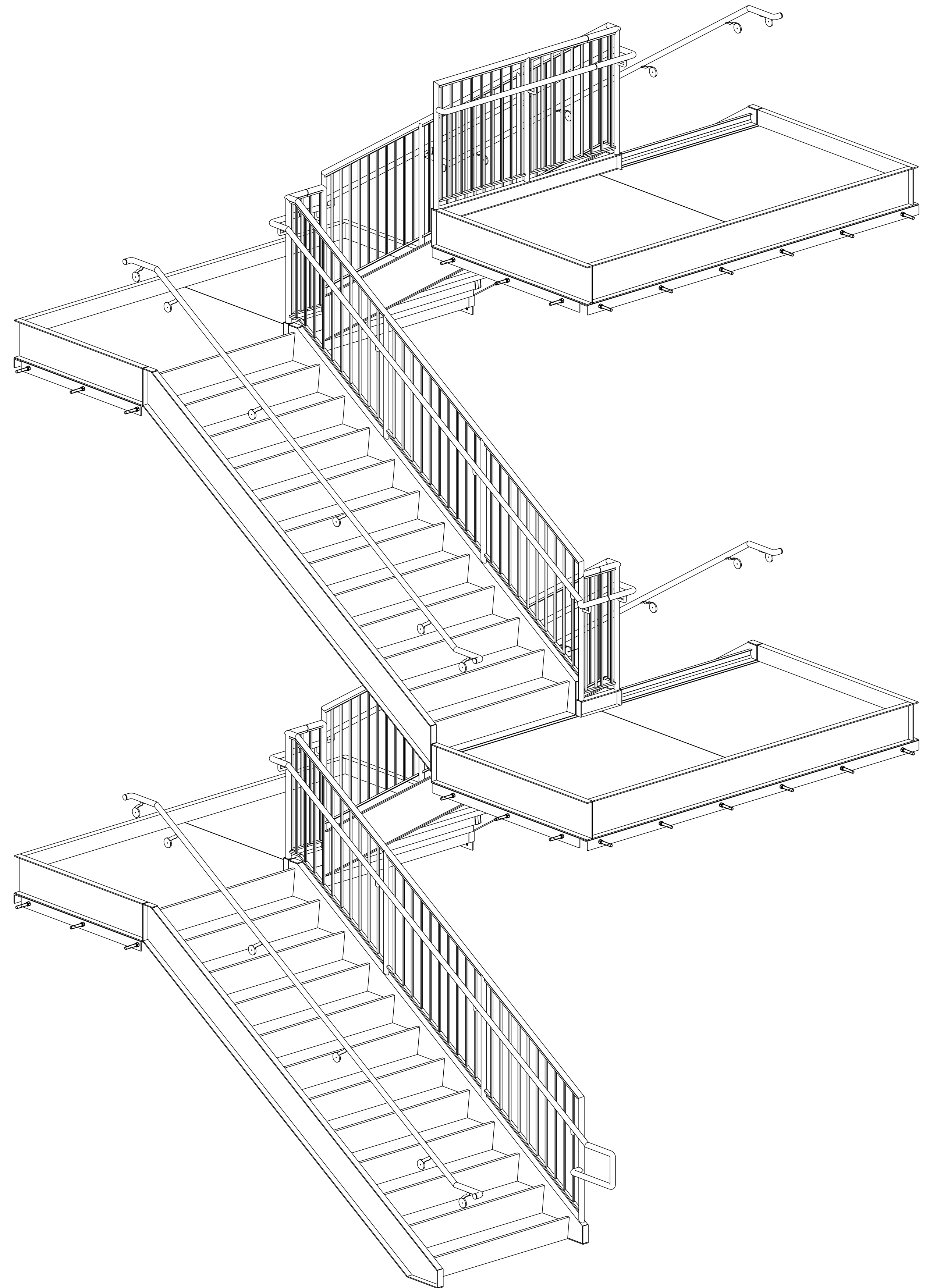

STAIR-B ISOMETRIC VIEW
 (AREA -B)
 (REF DWG :A9.2)

DESCRIPTION: STAIR-B PLAN ISOMETRIC VIEW	
JOB: SHANNODALE RETIREMENT CENTER	
CUSTOMER: -	ARCHITECT: COOPER ARCHITECTURE
Tennessee River Steel, LLC. Post Office Box 639 Hollywood, AL. 35752 Phone: (256) 574-2755 Fax: (256) 259-4247	
DRAWN BY	DATE
BVK	28.03.2019
CHKD. BY	DATE
VHR	28.03.2019
DRG. NO.	REV.
E201	A

A	03/28/2019	For Approval
REV.	DATE	DESCRIPTION

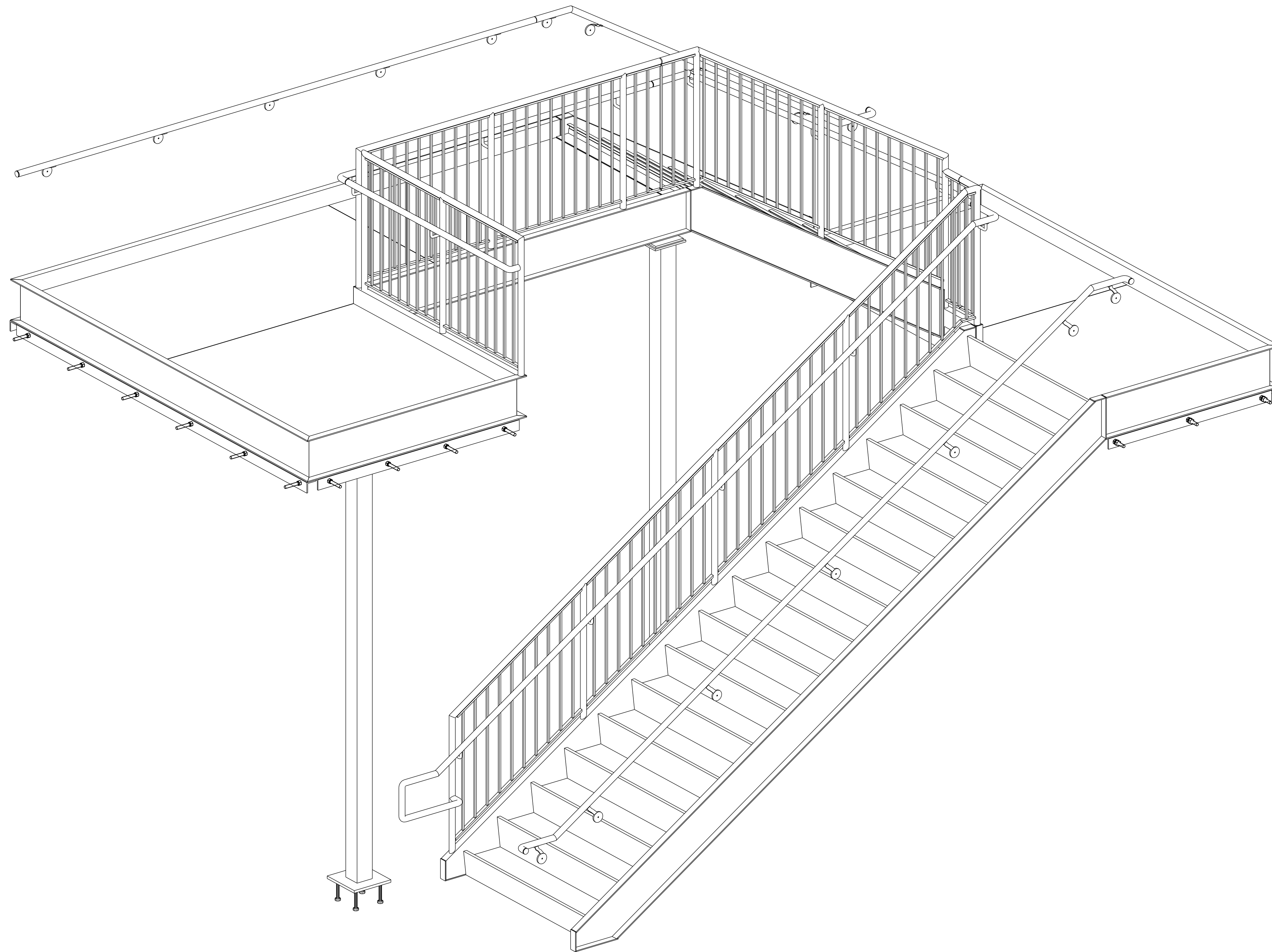

STAIR-C ISOMETRIC VIEW
 (AREA-C)
 (REF DWG:A9.3)

DESCRIPTION: STAIR-C PLAN ISOMETRIC VIEW	
JOB: SHANNODALE RETIREMENT CENTER	
CUSTOMER: -	ARCHITECT: COOPER ARCHITECTURE
Tennessee River Steel, LLC. Post Office Box 639 Hollywood, AL. 35752 Phone: (256) 574-2755 Fax: (256) 259-4247	
DRAWN BY	DATE
BVK	28.03.2019
CHKD BY	DATE
VHR	28.03.2019
DRG. NO.	REV.
E301	A

A	03/28/2019	For Approval
REV.	DATE	DESCRIPTION

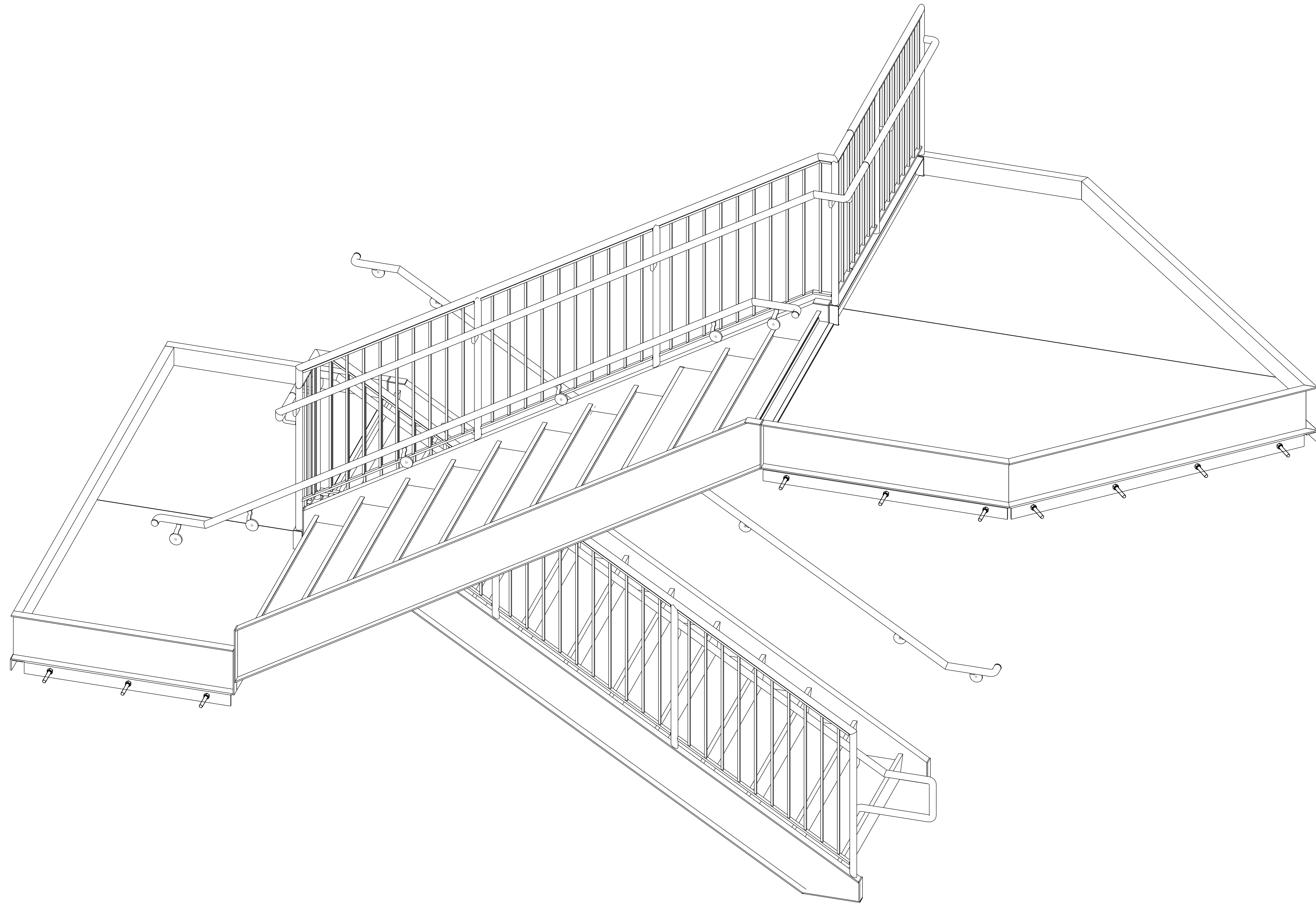

STAIR D-1 ISOMETRIC VIEW
 (AREA -D.1)
 (REF DWG-A9.4)

DESCRIPTION: STAIR D-1 ISOMETRIC VIEW	
JOB: SHANNODALE RETIREMENT CENTER	
CUSTOMER: -	ARCHITECT: COOPER ARCHITECTURE
Tennessee River Steel, LLC. Post Office Box 639 Hollywood, AL. 35752 Phone: (256) 574-2755 Fax: (256) 259-4247	
DRAWN BY	DATE
BVK	28.03.2019
CHKD. BY	DATE
VHR	28.03.2019
DRG. NO.	REV.
E401	A

A	03/28/2019	For Approval
REV.	DATE	DESCRIPTION

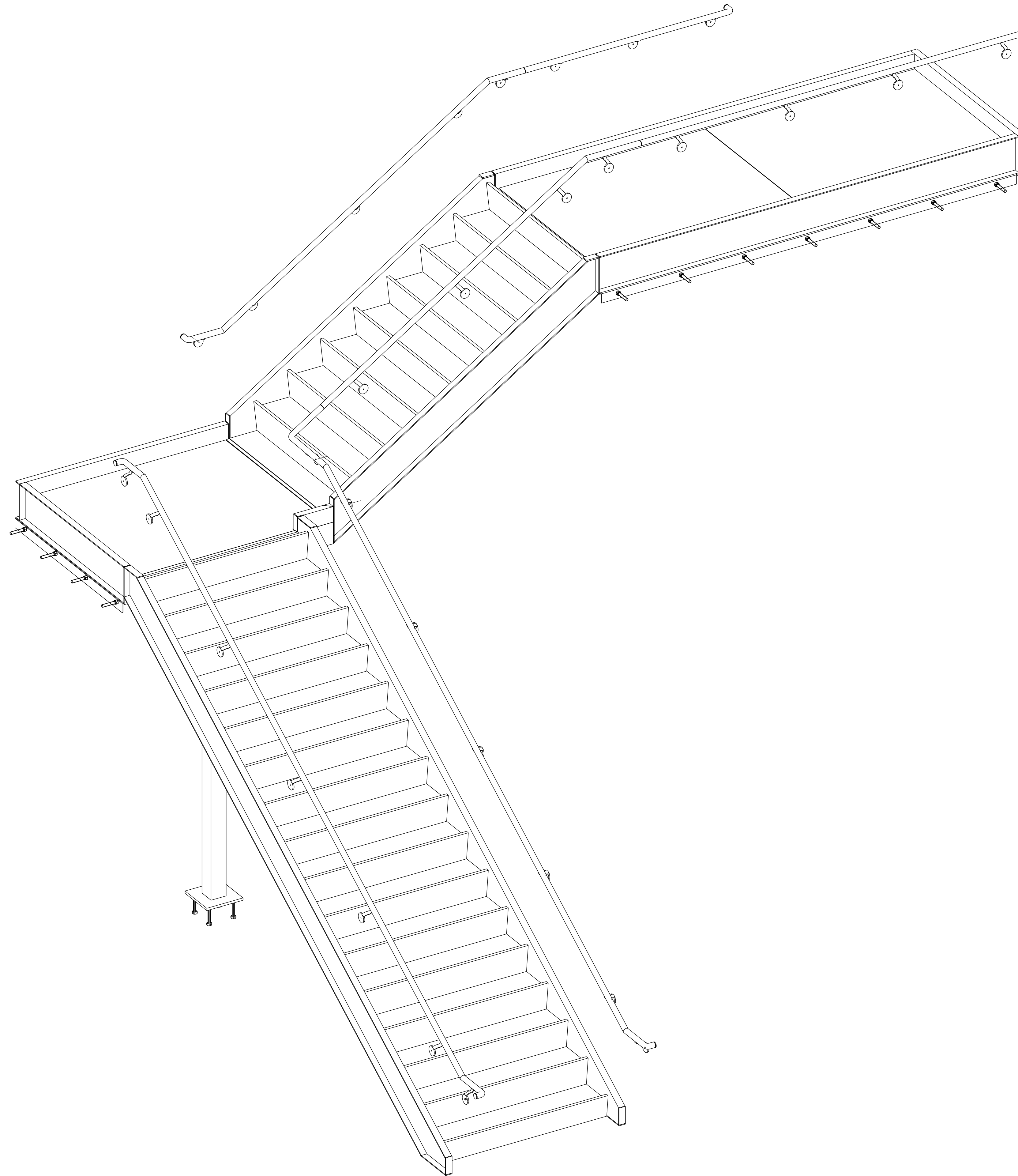

STAIR D-2 ISOMETRIC VIEW
 (AREA-D.2)
 (REF DWG:A9.6)

DESCRIPTION: STAIR D-2 ISOMETRIC VIEW

JOB: SHANNODALE RETIREMENT CENTER

CUSTOMER: - ARCHITECT: COOPER ARCHITECTURE

Tennessee River Steel, LLC.
 Post Office Box 639
 Hollywood, AL. 35752
 Phone: (256) 574-2755 Fax: (256) 259-4247

DRAWN BY	DATE
BVK	28.03.2019
CHKD. BY	DATE
VHR	28.03.2019
DRG. NO.	REV.
E501	A

A	03/28/2019	For Approval
REV.	DATE	DESCRIPTION

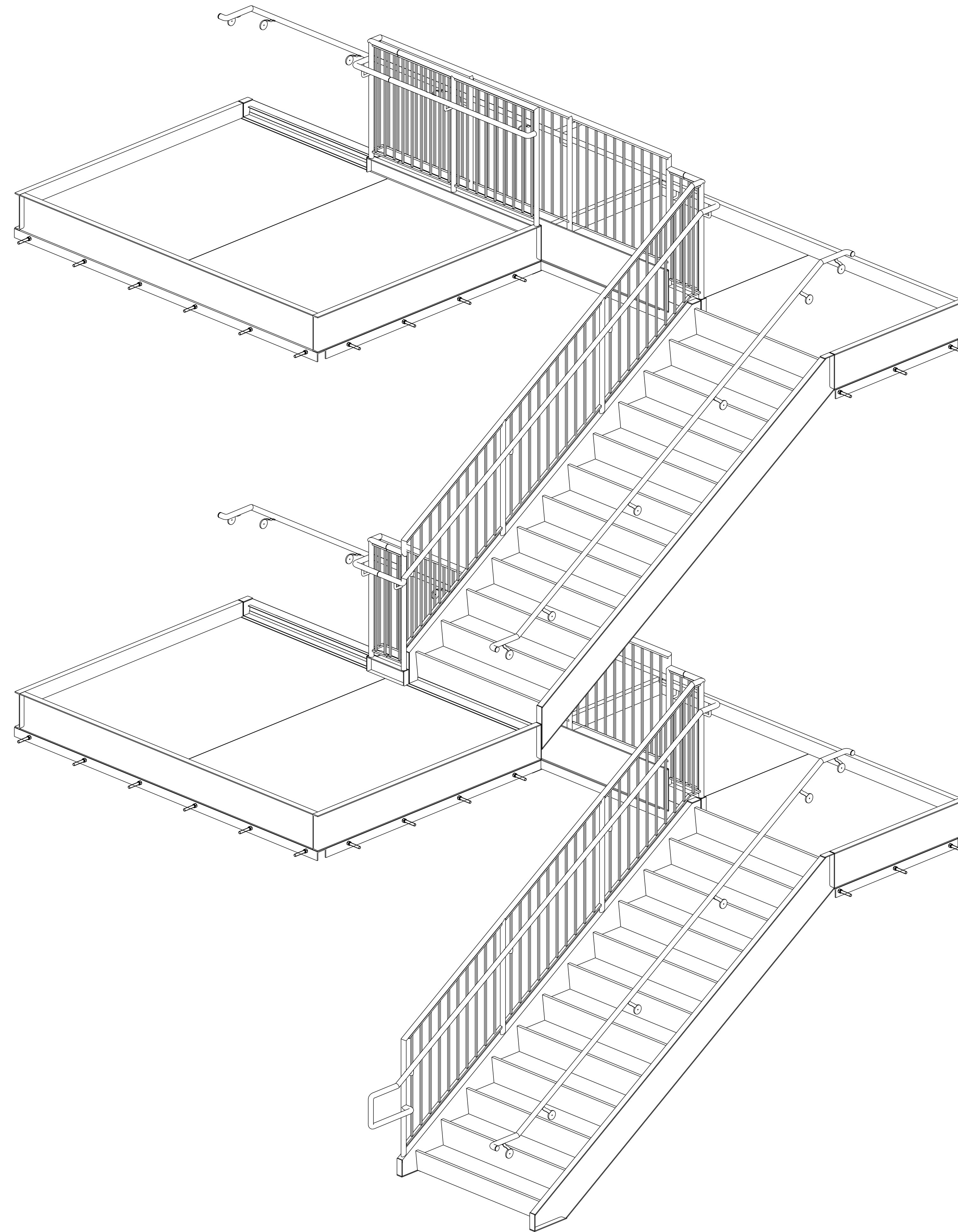

STAIR G ISOMETRIC VIEW
 (AREA-G)
 (REF.DWG:A9.7)

DESCRIPTION: ISOMETRIC VIEW	
JOB: SHANNODALE RETIREMENT CENTER	
CUSTOMER: -	ARCHITECT: COOPER ARCHITECTURE
Tennessee River Steel, LLC. Post Office Box 639 Hollywood, AL. 35752 Phone: (256) 574-2755 Fax: (256) 259-4247	
DRAWN BY	DATE
BVK	28.03.2019
CHKD. BY	DATE
VHR	28.03.2019
DRG. NO.	REV.
E601	A

A	03/28/2019	For Approval
REV.	DATE	DESCRIPTION

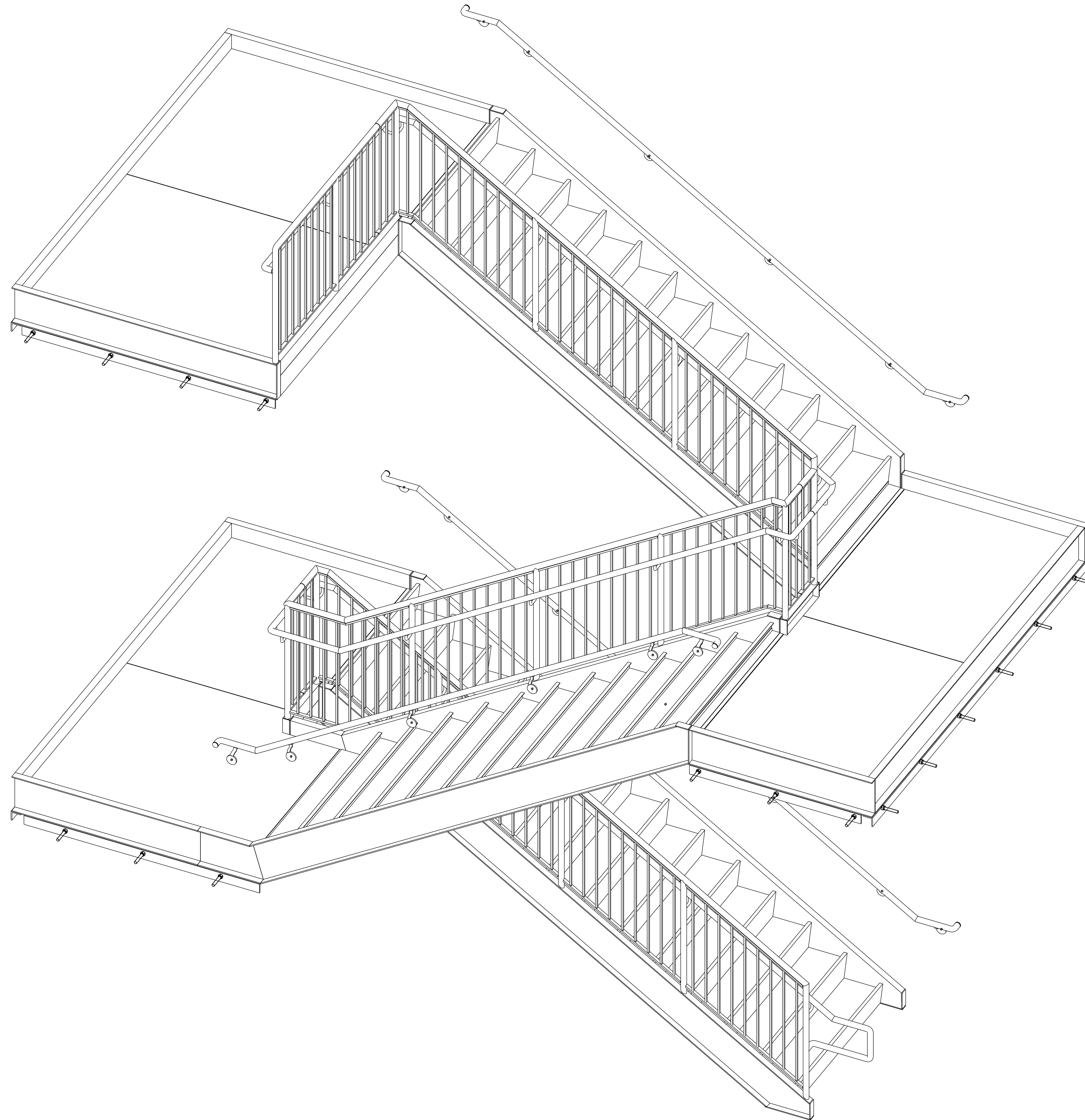

STAIR-H ISOMETRIC VIEW
 (AREA-H)
 (REF:A9.8)

DESCRIPTION: STAIR-H ISOMETRIC VIEW	
JOB: SHANNODALE RETIREMENT CENTER	
CUSTOMER: -	ARCHITECT: COOPER ARCHITECTURE
Tennessee River Steel, LLC. Post Office Box 639 Hollywood, AL. 35752 Phone: (256) 574-2755 Fax: (256) 259-4247	
DRAWN BY	DATE
BVK	28.03.2019
CHKD. BY	DATE
VHR	28.03.2019
DRG. NO.	REV.
E701	A

A	03/28/2019	For Approval
REV.	DATE	DESCRIPTION

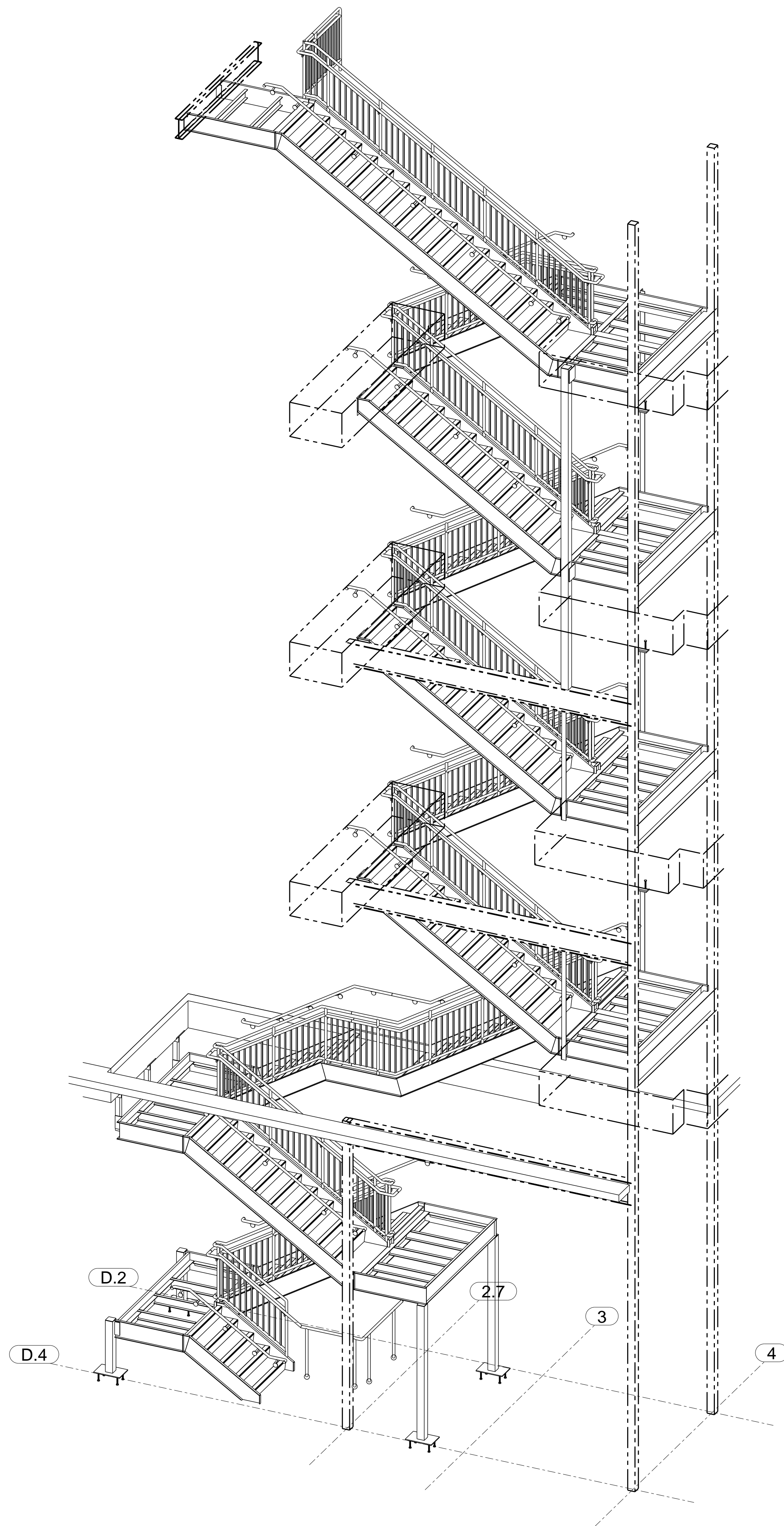

ISOMETRIC VIEW
(MAIN BUILDING REF STAIR#101)

DESCRIPTION: ISOMETRIC VIEW	
JOB: THE REDSTONE FEDERAL CREDIT UNION	
CUSTOMER: ROBINS AND MORTON	ARCHITECT: KPS GROUP, INC.
DRAWN BY: RAJ	DATE: 07.03.2019
CHKD. BY: VHR	DATE: 07.03.2019
DRG. NO. E101	REV. A

Tennessee River Steel, LLC.
Post Office Box 639
Hollywood, AL. 35752
Phone: (256) 574-2755 Fax: (256) 259-4247

REV.	DATE	DESCRIPTION
A	03/07/2019	For Approval

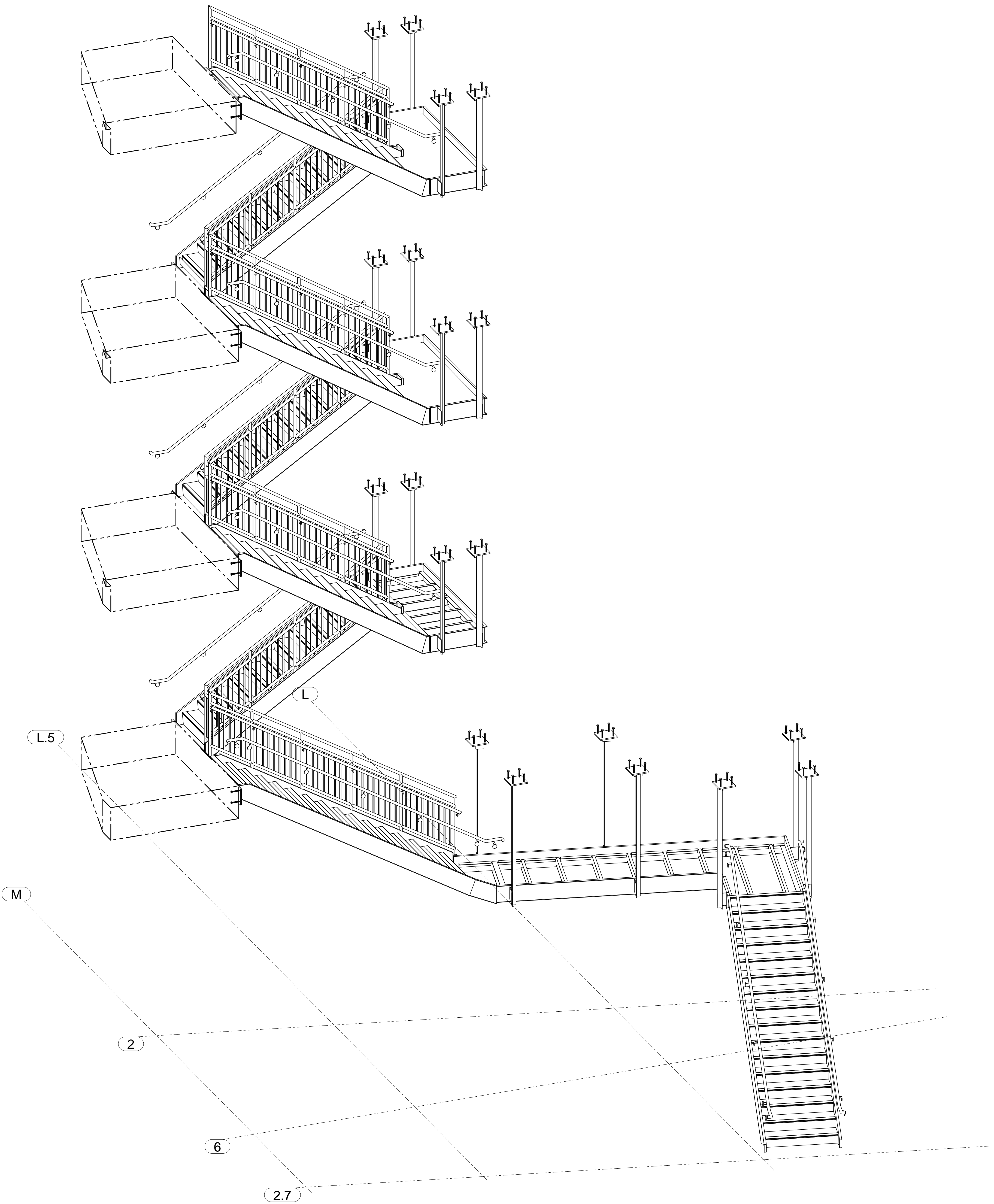

ISOMETRIC VIEW
STAIR-102 (MAIN BUILDING)

DESCRIPTION: ISOMETRIC VIEW	
JOB: THE REDSTONE FEDERAL CREDIT UNION	
CUSTOMER: ROBINS AND MORTON	ARCHITECT: KPS GROUP, INC.
Tennessee River Steel, LLC. Post Office Box 639 Hollywood, AL. 35752 Phone: (256) 574-2755 Fax: (256) 259-4247	
DRAWN BY	DATE
RAJ	05.03.2019
CHKD. BY	DATE
VHR	05.03.2019
DRG. NO.	REV.
E201	A

A	03/05/2019	For Approval
REV.	DATE	DESCRIPTION

TERRA STRUCTURES

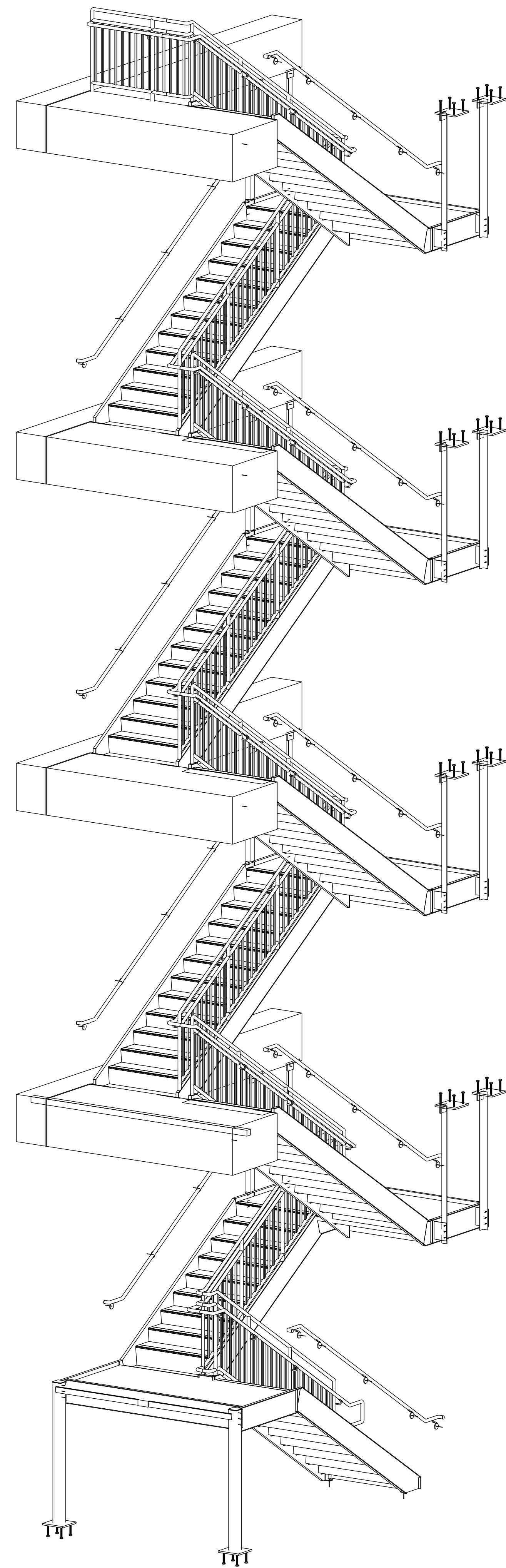

ISOMETRIC VIEW
STAIR-107 (MAIN BUILDING)

DESCRIPTION: ISOMETRIC VIEW	
JOB: THE REDSTONE FEDERAL CREDIT UNION	
CUSTOMER: ROBINS AND MORTON	ARCHITECT: KPS GROUP, INC.
DRAWN BY: RAJ	DATE: 07.03.2019
CHKD. BY: VHR	DATE: 07.03.2019
<p style="text-align: center;">Tennessee River Steel, LLC. Post Office Box 639 Hollywood, AL. 35752 Phone: (256) 574-2755 Fax: (256) 259-4247</p>	
DRG. NO. E301	REV. A

REV.	DATE	DESCRIPTION
A	03/07/2019	For Approval